

Finished Assembly

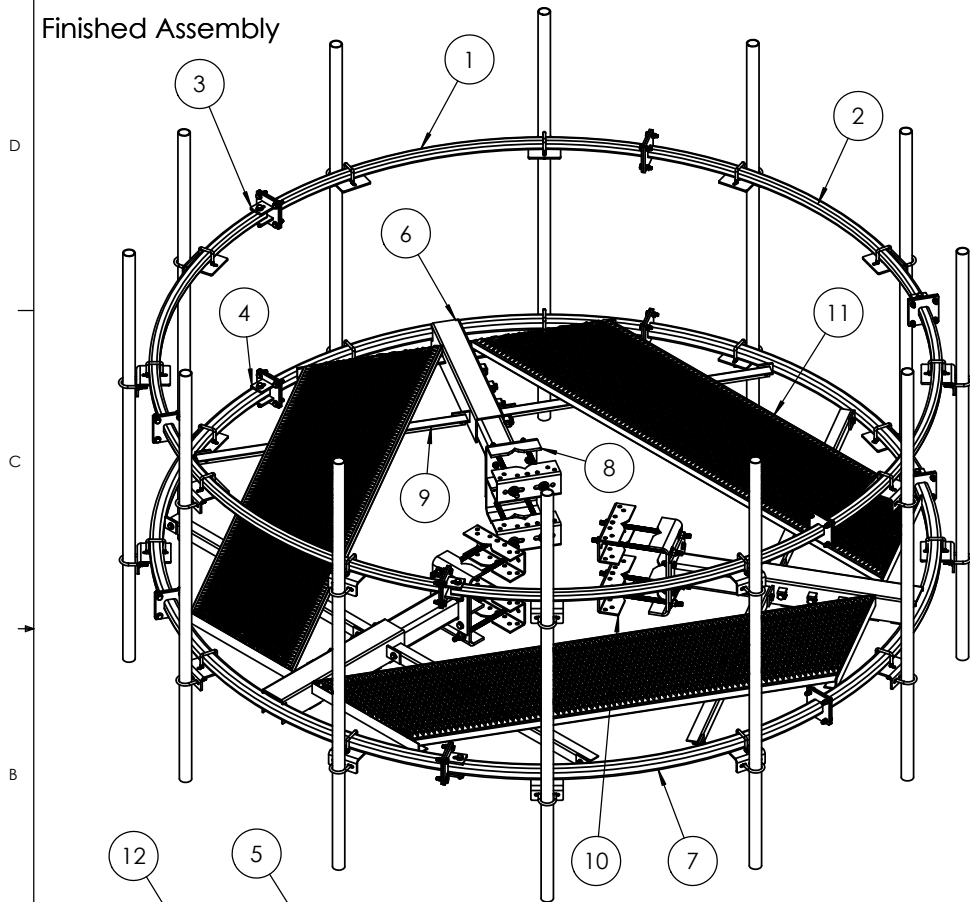

Grating Attachment Detail

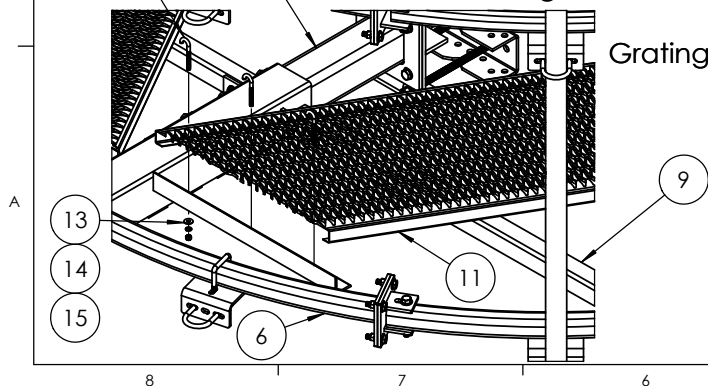

ITEM NO.	PART NUMBER	DESCRIPTION	QTY.
1	K1515KT-03	Handrail curve weldment with two plates	3
2	K1515KT-07	Handrail curve weldment with one plate	3
3	K1515KT-06	Swivel foot, 2"	3
4	K1515KT-04	Swivel foot, 2.5"	3
5	K1515KT-10L	Arm for Rotatable Platform	3
6	K1515KT-01 test	Slider curve weldment	3
7	K1515KT-02 test	Face curve weldment with one plate	3
8	K1515KT-15	Guy Tower Bracket, T1515KT-G	3
9	K1515KT-12 mod	Modified Angle	6
10	K1690KT-03	Channel for Sector Frame	6
11	T3900KT10	GRIPSTRUT, 2" x 24 x 10', .14 gauge	3
12	K9925KT	J-Bolt, 3/8", 8" long w/ 6-1/2" threads	18
13	H3012KT38G	Flat Washer, 3/8", HDG	18
14	H3002KT38G	Lock Washer, 3/8", HDG	18
15	H2002KT38G	Nut, hex heavy 3/8", HDG	18
16	H1026KT2GA3	Bolt, 1/2" x 2" (A325) HDG	60
17	H3012KT12GSAE	Flat washer, hardened, 1/2", SAE, HDG	108
18	H3002KT12G	Lock washer, 1/2" HDG	114
19	H2002KT12GA3	Nut, hex heavy 1/2" HDG A325	108
20	H1029KT214GA3	Bolt, 5/8"x2-1/4", hex, A325, HDG	21
21	H1029KT414GA3	Bolt, 5/8" x 4-1/4", A325, HDG	3
22	H1029KT434GA3	Bolt, 5/8" x 4-3/4", A325, HDG	3
23	H3012KT58GSA3	Flat washer, 5/8", SAE (A325), HDG	48
24	H3002KT58G	Lock washer, 5/8", HDG	21
25	H2002KT58GA3	Nut, 5/8"HH, HDG (A325)	27
26	K2320KT18i	Threaded rod 3/4"x18", HDG, ASTM A193 B7	12
27	H3012KT34GSA3	Flat washer, 3/4", SAE (A325), HDG	24
28	H3002KT34G	Lock washer, 3/4", HDG	24
29	H2002KT34GA3	Nut, 3/4" HH, HDG (A325)	24
30	K1029KT214-4	5/8" x 2-1/4" A325 bolt kit (4 bolts)	1
31	K1708KT35	Crossover angle mount, 2-3/8" thru 2-7/8"	24
32	K7941KT4-1	U-bolt kit, 2-3/8" OD pipe, (1 U-bolt)	24
33	H7940KT234SQ	1/2" Sq U-bolt for 2.5" Sq tube	12
34	H7940KT214SQ	1/2" Sq U-Bolt for 2" Sq Tube	12

Weight without Pipes: 1767.4 lbs

Weight with (12) 2-3/8"OD, 8' long Pipes: 2219.4 lbs



3431 Novis Pointe Acworth, Ga 30101
(770) 975-0500 office (770) 974-5100 fax

UNLESS OTHERWISE SPECIFIED:
DIMENSIONS ARE IN INCHES
TOLERANCES:
FRACTIONAL: ± 1/32
ANGULAR: ± 2°
ONE PLACE DECIMAL: ± .06
TWO PLACE DECIMAL: ± .03
THREE PLACE DECIMAL: ± .010

INTERPRET GEOMETRIC TOLERANCING PER:

MATERIAL

FINISH

DO NOT SCALE DRAWING

NAME	DATE
DRAWN KAR	3/20/19
CHECKED	
ENG APPR.	
MFG APPR.	

PROPRIETARY AND CONFIDENTIAL

THE INFORMATION CONTAINED IN THIS DRAWING IS THE SOLE PROPERTY OF KENWOOD TELECOM. ANY REPRODUCTION IN PART OR AS A WHOLE WITHOUT THE WRITTEN PERMISSION OF KENWOOD TELECOM IS PROHIBITED.



TITLE:
Circular platform for guyed tower with handrail. Includes hardware for 12 pipes 2-3/8" OD."

SIZE	DWG. NO.	REV
	T1515KT-G	A
SCALE: 1:24 FINISHED WEIGHT: SEE NOTE		SHEET 1 OF 4

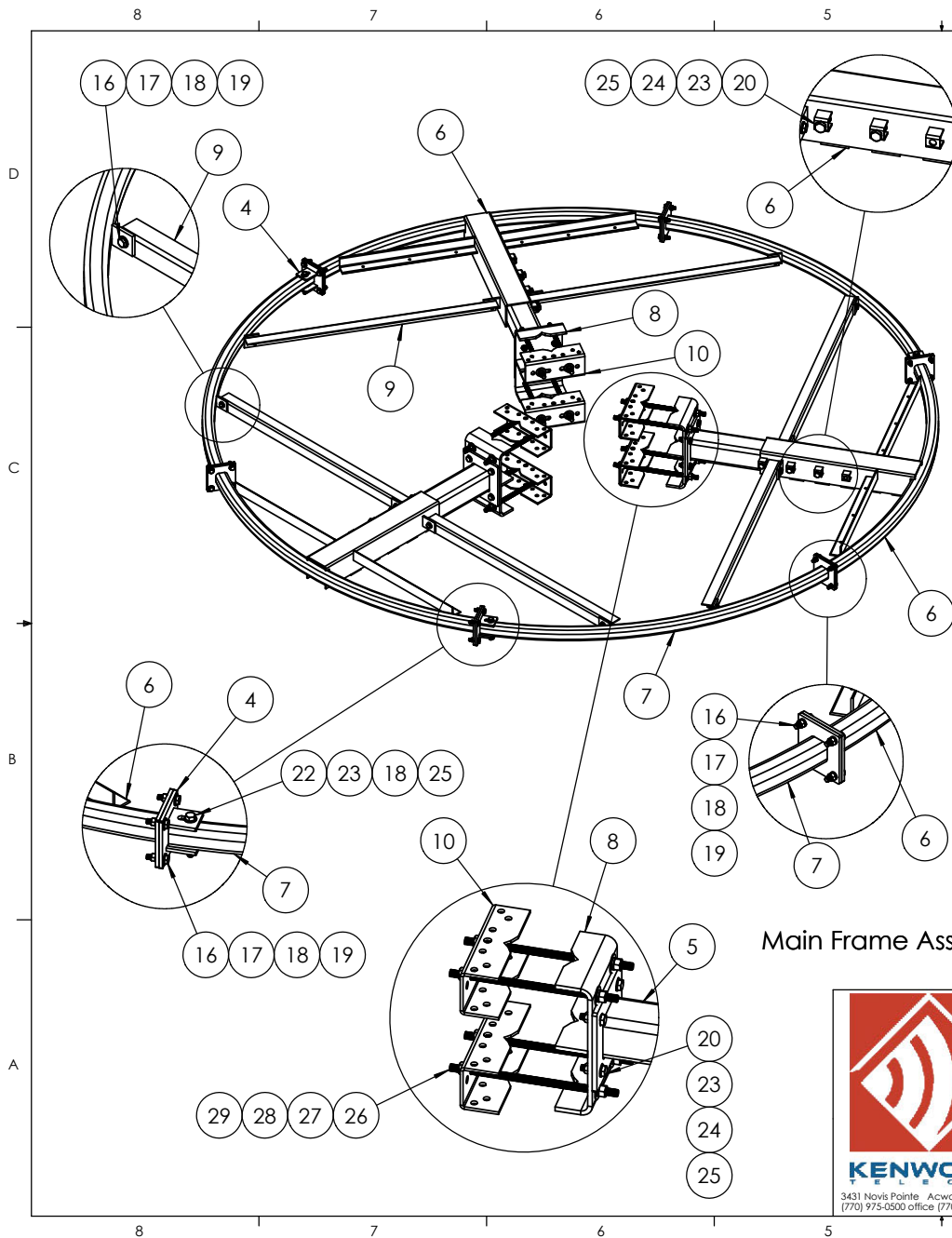

ITEM NO.	PART NUMBER	DESCRIPTION	QTY.
1	K1515KT-03	Handrail curve weldment with two plates	3
2	K1515KT-07	Handrail curve weldment with one plate	3
3	K1515KT-06	Swivel foot, 2"	3
4	K1515KT-04	Swivel foot, 2.5"	3
5	K1515KT-10L	Arm for Rotatable Platform	3
6	K1515KT-01 test	Slider curve weldment	3
7	K1515KT-02 test	Face curve weldment with one plate	3
8	K1515KT-15	Guy Tower Bracket, T1515KT-G	3
9	K1515KT-12 mod	Modified Angle	6
10	K1690KT-03	Channel for Sector Frame	6
11	T3900KT10	GRIPSTRUT, 2" x 24 x 10', 14 gauge	3
12	K9925KT	J-Bolt, 3/8", 8" long w/ 6-1/2" threads	18
13	H3012KT38G	Flat Washer, 3/8", HDG	18
14	H3002KT38G	Lock Washer, 3/8", HDG	18
15	H2002KT38G	Nut, hex heavy 3/8", HDG	18
16	H1026KT2GA3	Bolt, 1/2" x 2" (A325) HDG	60
17	H3012KT12GSAE	Flat washer, hardened, 1/2", SAE, HDG	108
18	H3002KT12G	Lock washer, 1/2" HDG	114
19	H2002KT12GA3	Nut, hex heavy 1/2" HDG A325	108
20	H1029KT214GA3	Bolt, 5/8"x2-1/4", hex, A325, HDG	21
21	H1029KT414GA3	Bolt, 5/8" x 4-1/4", A325, HDG	3
22	H1029KT434GA3	Bolt, 5/8" x 4-3/4", A325, HDG	3
23	H3012KT58GSA3	Flat washer, 5/8", SAE (A325), HDG	48
24	H3002KT58G	Lock washer, 5/8", HDG	21
25	H2002KT58GA3	Nut, 5/8"HH, HDG (A325)	27
26	K2320KT18i	Threaded rod 3/4"x18", HDG, ASTM A193 B7	12
27	H3012KT34GSA3	Flat washer, 3/4", SAE (A325), HDG	24
28	H3002KT34G	Lock washer, 3/4", HDG	24
29	H2002KT34GA3	Nut, 3/4" HH, HDG (A325)	24
30	K1029KT214-4	5/8" x 2-1/4" A325 bolt kit (4 bolts)	1
31	K1708KT35	Crossover angle mount, 2-3/8" thru 2-7/8"	24
32	K7941KT4-1	U-bolt kit, 2-3/8" OD pipe, (1 U-bolt)	24
33	H7940KT234SQ	1/2" Sq U-bolt for 2.5" Sq tube	12
34	H7940KT214SQ	1/2" Sq U-Bolt for 2" Sq Tube	12

Item #8, length must be field cut to accommodate larger size towers.
3 side bolts on Item #6 must be used to maintain structural integrity.

Main Frame Assembly Detail



3431 Novis Pointe Acworth, Ga 30101
(770) 975-0500 office (770) 974-5100 fax

UNLESS OTHERWISE SPECIFIED:
DIMENSIONS ARE IN INCHES
TOLERANCES:
FRACTIONAL: ± 1/32
ANGULAR: ± 2°
ONE PLACE DECIMAL: ± .06
TWO PLACE DECIMAL: ± .03
THREE PLACE DECIMAL: ± .010
INTERPRET GEOMETRIC TOLERANCING PER:
MATERIAL:
FINISH:
DO NOT SCALE DRAWING

NAME: KAR
DATE: 3/20/19
DRAWN:
CHECKED:
ENG APPR.:
MFG APPR.:
PROPRIETARY AND CONFIDENTIAL
THE INFORMATION CONTAINED IN THIS DRAWING IS THE SOLE PROPERTY OF KENWOOD TELECOM. ANY REPRODUCTION IN PART OR AS A WHOLE WITHOUT THE WRITTEN PERMISSION OF KENWOOD TELECOM IS PROHIBITED.

KENWOOD TELECOM

TITLE:
Circular platform for guyed tower with handrail. Includes hardware for 12 pipes 2-3/8" OD."

SIZE: DWG. NO. **T1515KT-G** REV **A**

SCALE: 1:24 FINISHED WEIGHT: SHEET 2 OF 4

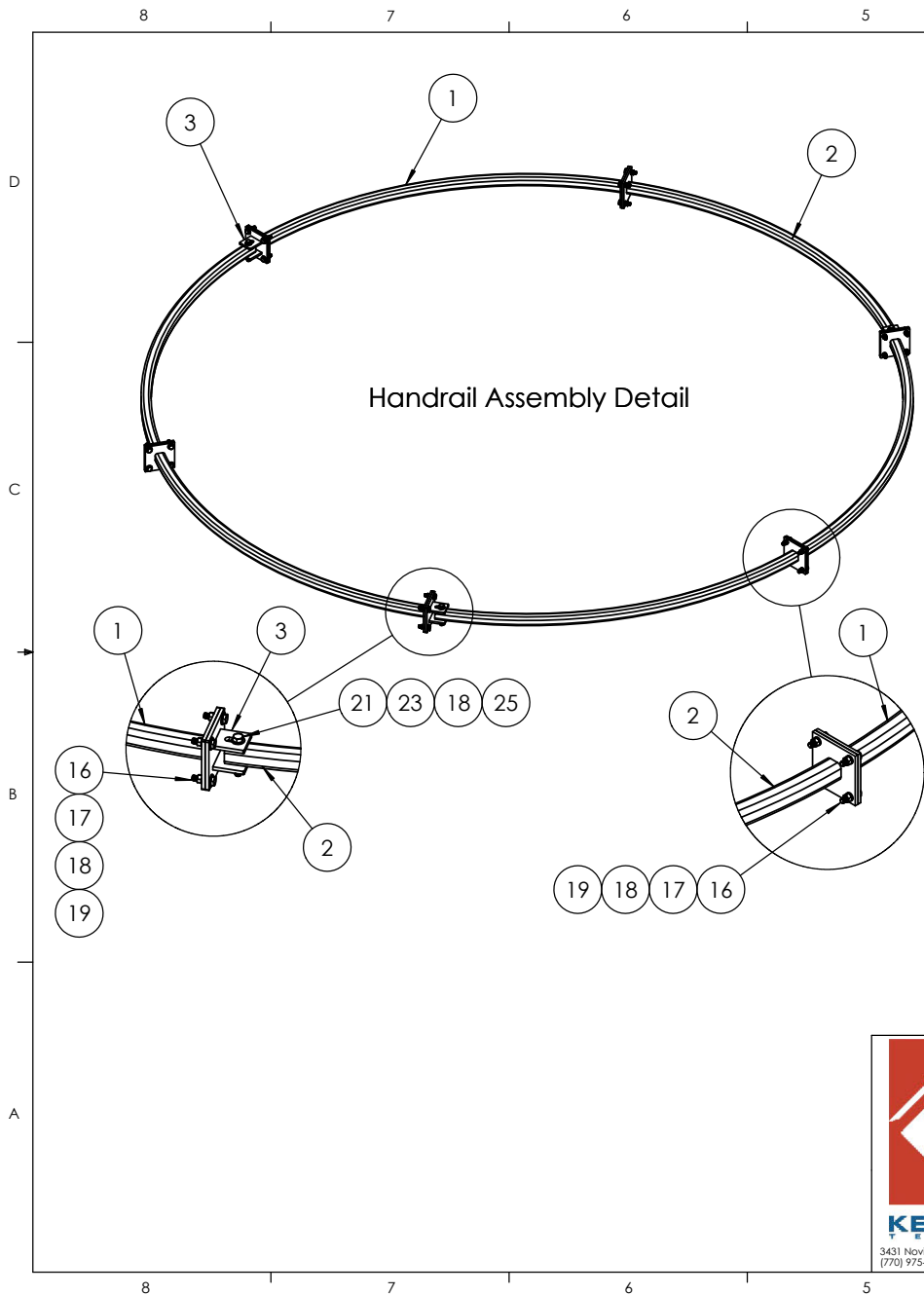

ITEM NO.	PART NUMBER	DESCRIPTION	QTY.
1	K1515KT-03	Handrail curve weldment with two plates	3
2	K1515KT-07	Handrail curve weldment with one plate	3
3	K1515KT-06	Swivel foot, 2"	3
4	K1515KT-04	Swivel foot, 2.5"	3
5	K1515KT-10L	Arm for Rotatable Platform	3
6	K1515KT-01 test	Slider curve weldment	3
7	K1515KT-02 test	Face curve weldment with one plate	3
8	K1515KT-15	Guy Tower Bracket, T1515KT-G	3
9	K1515KT-12 mod	Modified Angle	6
10	K1690KT-03	Channel for Sector Frame	6
11	T3900KT10	GRIPSTRUT, 2" x 24 x 10', 14 gauge	3
12	K9925KT	J-Bolt, 3/8", 8" long w/ 6-1/2" threads	18
13	H3012KT38G	Flat Washer, 3/8", HDG	18
14	H3002KT38G	Lock Washer, 3/8", HDG	18
15	H2002KT38G	Nut, hex heavy 3/8", HDG	18
16	H1026KT2GA3	Bolt, 1/2" x 2" (A325) HDG	60
17	H3012KT12GSAE	Flat washer, hardened, 1/2", SAE, HDG	108
18	H3002KT12G	Lock washer, 1/2" HDG	114
19	H2002KT12GA3	Nut, hex heavy 1/2" HDG A325	108
20	H1029KT214GA3	Bolt, 5/8"x2-1/4", hex, A325, HDG	21
21	H1029KT414GA3	Bolt, 5/8" x 4-1/4", A325, HDG	3
22	H1029KT434GA3	Bolt, 5/8" x 4-3/4", A325, HDG	3
23	H3012KT58GSA3	Flat washer, 5/8", SAE (A325), HDG	48
24	H3002KT58G	Lock washer, 5/8", HDG	21
25	H2002KT58GA3	Nut, 5/8"HH, HDG (A325)	27
26	K2320KT18i	Threaded rod 3/4"x18", HDG, ASTM A193 B7	12
27	H3012KT34GSA3	Flat washer, 3/4", SAE (A325), HDG	24
28	H3002KT34G	Lock washer, 3/4", HDG	24
29	H2002KT34GA3	Nut, 3/4" HH, HDG (A325)	24
30	K1029KT214-4	5/8" x 2-1/4" A325 bolt kit (4 bolts)	1
31	K1708KT35	Crossover angle mount, 2-3/8" thru 2-7/8"	24
32	K7941KT4-1	U-bolt kit, 2-3/8" OD pipe, (1 U-bolt)	24
33	H7940KT2345Q	1/2" Sq Ubolt for 2.5" Sq tube	12
34	H7940KT2145Q	1/2" Sq U-Bolt for 2" Sq Tube	12



UNLESS OTHERWISE SPECIFIED:
 DIMENSIONS ARE IN INCHES
 TOLERANCES:
 FRACTIONAL: ± 1/32
 ANGULAR: ± 2°
 ONE PLACE DECIMAL: ± .06
 TWO PLACE DECIMAL: ± .03
 THREE PLACE DECIMAL: ± .010

INTERPRET GEOMETRIC TOLERANCING PER:

MATERIAL

FINISH

DO NOT SCALE DRAWING

NAME	DATE
DRAWN	KAR 3/20/19
CHECKED	
ENG APPR.	
MFG APPR.	

PROPRIETARY AND CONFIDENTIAL

THE INFORMATION CONTAINED IN THIS DRAWING IS THE SOLE PROPERTY OF KENWOOD TELECOM. ANY REPRODUCTION IN PART OR AS A WHOLE WITHOUT THE WRITTEN PERMISSION OF KENWOOD TELECOM IS PROHIBITED.

KENWOOD TELECOM

TITLE:
Circular platform for guyed tower with handrail. Includes hardware for 12 pipes 2-3/8" OD."

SIZE	DWG. NO.	REV
	T1515KT-G	A

SCALE: 1:24 FINISHED WEIGHT: SHEET 3 OF 4

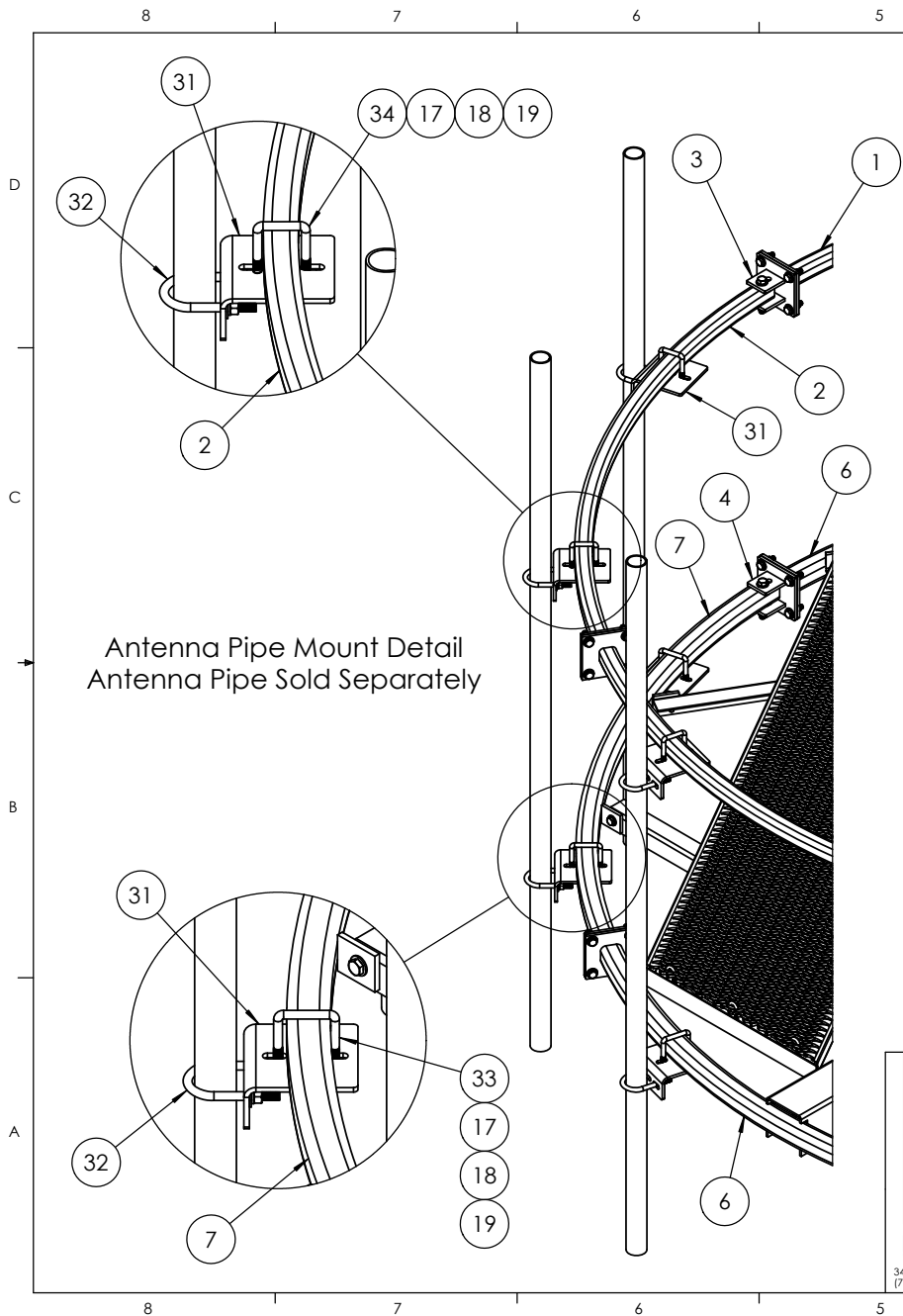

ITEM NO.	PART NUMBER	DESCRIPTION	QTY.
1	K1515KT-03	Handrail curve weldment with two plates	3
2	K1515KT-07	Handrail curve weldment with one plate	3
3	K1515KT-06	Swivel foot, 2"	3
4	K1515KT-04	Swivel foot, 2.5"	3
5	K1515KT-10L	Arm for Rotatable Platform	3
6	K1515KT-01 test	Slider curve weldment	3
7	K1515KT-02 test	Face curve weldment with one plate	3
8	K1515KT-15	Guy Tower Bracket, T1515KT-G	3
9	K1515KT-12 mod	Modified Angle	6
10	K1690KT-03	Channel for Sector Frame	6
11	T3900KT10	GRIPSTRUT, 2" x 24 x 10', 14 gauge	3
12	K9925KT	J-Bolt, 3/8", 8" long w/ 6-1/2" threads	18
13	H3012KT38G	Flat Washer, 3/8", HDG	18
14	H3002KT38G	Lock Washer, 3/8", HDG	18
15	H2002KT38G	Nut, hex heavy 3/8", HDG	18
16	H1026KT2GA3	Bolt, 1/2" x 2" (A325) HDG	60
17	H3012KT12GSAE	Flat washer, hardened, 1/2", SAE, HDG	108
18	H3002KT12G	Lock washer, 1/2" HDG	114
19	H2002KT12GA3	Nut, hex heavy 1/2" HDG A325	108
20	H1029KT214GA3	Bolt, 5/8"x2-1/4", hex, A325, HDG	21
21	H1029KT414GA3	Bolt, 5/8" x 4-1/4", A325, HDG	3
22	H1029KT434GA3	Bolt, 5/8" x 4-3/4", A325, HDG	3
23	H3012KT58GSA3	Flat washer, 5/8", SAE (A325), HDG	48
24	H3002KT58G	Lock washer, 5/8", HDG	21
25	H2002KT58GA3	Nut, 5/8"HH, HDG (A325)	27
26	K2320KT18i	Threaded rod 3/4"x18", HDG, ASTM A193 B7	12
27	H3012KT34GSA3	Flat washer, 3/4", SAE (A325), HDG	24
28	H3002KT34G	Lock washer, 3/4", HDG	24
29	H2002KT34GA3	Nut, 3/4" HH, HDG (A325)	24
30	K1029KT214-4	5/8" x 2-1/4" A325 bolt kit (4 bolts)	1
31	K1708KT35	Crossover angle mount, 2-3/8" thru 2-7/8"	24
32	K7941KT4-1	U-bolt kit, 2-3/8" OD pipe, (1 U-bolt)	24
33	H7940KT234SQ	1/2" Sq Ubolt for 2.5" Sq tube	12
34	H7940KT214SQ	1/2" Sq U-Bolt for 2" Sq Tube	12



UNLESS OTHERWISE SPECIFIED:
DIMENSIONS ARE IN INCHES
TOLERANCES:
FRACTIONAL: ± 1/32
ANGULAR: ± 2°
ONE PLACE DECIMAL: ± .06
TWO PLACE DECIMAL: ± .03
THREE PLACE DECIMAL: ± .010

INTERPRET GEOMETRIC TOLERANCING PER:

MATERIAL

FINISH

DO NOT SCALE DRAWING

NAME	DATE
DRAWN KAR	3/20/19
CHECKED	
ENG APPR.	
MFG APPR.	

PROPRIETARY AND CONFIDENTIAL

THE INFORMATION CONTAINED IN THIS DRAWING IS THE SOLE PROPERTY OF KENWOOD TELECOM. ANY REPRODUCTION IN PART OR AS A WHOLE WITHOUT THE WRITTEN PERMISSION OF KENWOOD TELECOM IS PROHIBITED.



KENWOOD TELECOM

TITLE:
Circular platform for guyed tower with handrail. Includes hardware for 12 pipes 2-3/8" OD."

SIZE	DWG. NO.	REV
	T1515KT-G	A
SCALE: 1:24 FINISHED WEIGHT:		SHEET 4 OF 4

8 7 6 5 4 3 2 1

D

D

C

C

B

B

A

A

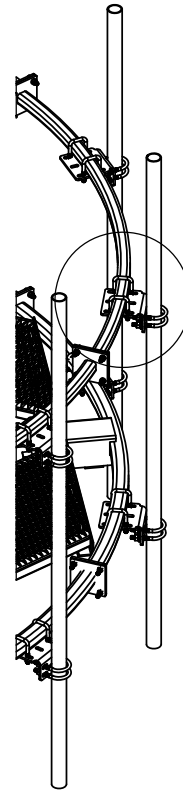
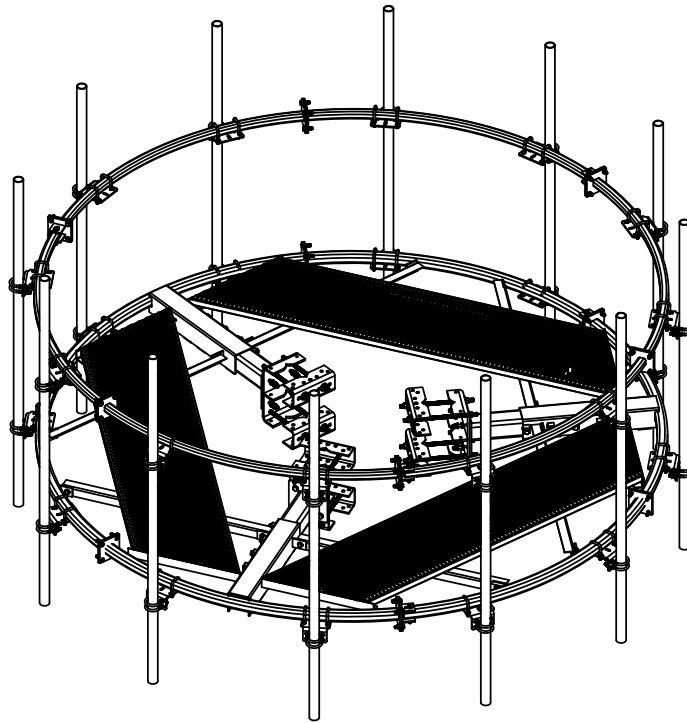

Double Square Tube Ubolts

Redesigned Bracket for Pipe Mount

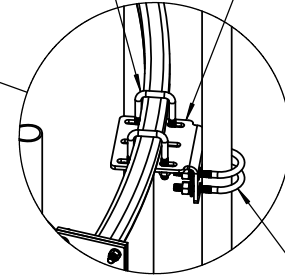

Double Pipe Ubolts



KENWOOD TELECOM
 3431 Novis Pointe Acworth, Ga 30101
 (770) 975-0500 office (770) 974-5100 fax

UNLESS OTHERWISE SPECIFIED:
 DIMENSIONS ARE IN INCHES
 TOLERANCES:
 FRACTIONAL: ± 1/32
 ANGULAR: ± 2°
 ONE PLACE DECIMAL: ± .06
 TWO PLACE DECIMAL: ± .03
 THREE PLACE DECIMAL: ± .010
 INTERPRET GEOMETRIC TOLERANCING PER:
 MATERIAL:
 FINISH:
 DO NOT SCALE DRAWING

NAME	DATE
KAR	6/18/20
CHECKED	
ENG APPR.	
MFG APPR.	
PROPRIETARY AND CONFIDENTIAL	
THE INFORMATION CONTAINED IN THIS DRAWING IS THE SOLE PROPERTY OF KENWOOD TELECOM. ANY REPRODUCTION IN PART OR AS A WHOLE WITHOUT THE WRITTEN PERMISSION OF KENWOOD TELECOM IS PROHIBITED.	

 KENWOOD TELECOM		
TITLE: Pipe Mount Addendum for Circle Platform		
SIZE	DWG. NO.	REV
SCALE: 1:30	T1515KT Addendum	-
FINISHED WEIGHT:		SHEET 1 OF 1

8 7 6 5 4 3 2 1